



AUTOBETANKUNG



KRAFTSTOFFMANAGEMENT-SYSTEM



KITS



PUMPEN



ZÄHLER



ZAPFVENTILZÄHLER

DELPHIN PRO

MERKMALE

- VOLLAUTOMATISCH
- KEIN BEDIENPERSONAL ERFORDERLICH
- 100% KOMPATIBEL MIT ALLEN FAHRZEUGEN*
- ROBUSTE KONSTRUKTION
- LEICHT MANÖVRIERBAR
- AUTOMATISCHE DURCHFLUSSREGELUNG

DELPHIN PRO ist das bekannteste AdBlue®-Fahrzeugbefüllsystem von PIUSI: es ermöglicht jeder Werkstatt, in die automatische AdBlue®-Fahrzeugbefüllung einzusteigen, sodass der Einsatz manueller Vorrichtungen der Vergangenheit angehört. Das kompakte, zuverlässige und robuste DELPHIN PRO kann unter allen Arbeitsbedingungen eingesetzt werden. Durch seine vollautomatische Funktion lässt sich ein AdBlue®-Tank in nur 2 Minuten auffüllen, darüber hinaus verhindert sein patentierter Auslauf das Auskristallisieren von AdBlue® und ist völlig reinigungs- und wartungsfrei.

LEISTUNGSPARAMETER

2-11 L/MIN

VOLUMENSTROM

AC

STROMVERSORGUNG

SPANNUNG

2M

SCHLAUHLÄNGE



DELPHIN PRO



VERPACKUNG

CODE	GEWICHT		VERPACKUNG		
	KG	LBS	MM	ZOLL	STCK./KARTON
FO010020B	37	81,5	770X1080X800	30,3X42X31,5	1
FO010021B	37	81,5	770X1080X800	30,3X42X31,5	1



ZAPFVENTILE



FILTERUNG



FLÜSSIGKEIT-SÜBERWACHUNG



SCHLAUCHAUFROLLER



ZUBEHÖR



MERCHANDISE



LUFT



FROSTSCHUTZ



AdBlue®



BIODIESEL



DIESEL



LEBENS.M.



BENZIN



SCHMIERM.



KEROSIN



ÖL



WASSER



WISCHERFLÜSS.

FUNCTIONING



1
EINSCHALTEN DES DELPHIN PRO



2
MIT DEM DIMMER VOLUMENSTROM EINSTELLEN



3
ANSCHLUSSSTUTZEN AUF DEN AUTOTANK AUFSTECKEN



4
DRÜCKEN SIE DIE REFILL-TASTE 5 SEK LANG



5
TANK IST VOLL: DELPHIN PRO STOPPT DAS BEFÜLLEN AUTOMATISCH

ABMESSUNGEN

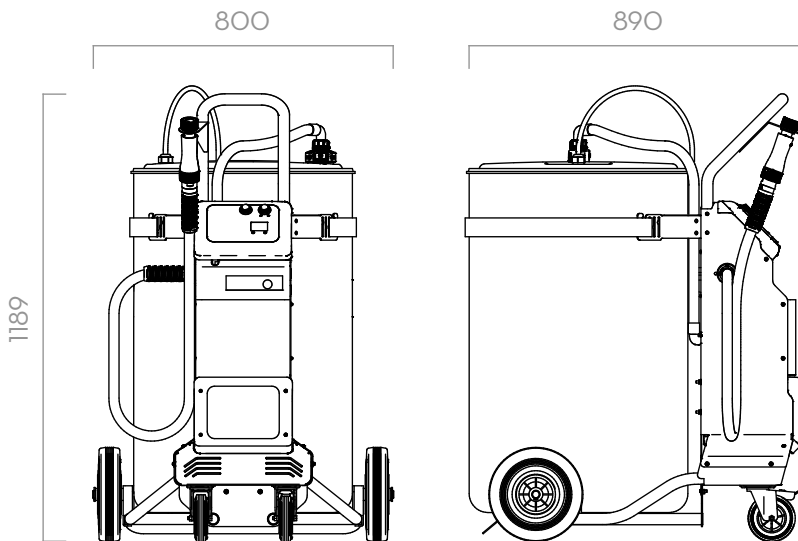

Maße in Millimetern

LIEFERUMFANG

- DELPHIN PRO EINHEIT
- AF2/SEC ANSCHLUSS
- BEDIENUNGSANLEITUNG

EINZELHEITEN



ISO-KONFORMER UNIVERSALSTECKVERBINDER



SEC-AUSFÜHRUNG VERFÜGBAR



DIGITALDURCHFLOßMESSER

MATERIALIEN

- PUMPE:
- GEHÄUSE: POLYPROPYLEN
- MEMBRAN: POLYPROPYLEN

TECHNISCHE DATEN

CODE	BESCHREIBUNG	FLÜSSIGKEIT-SART	VOLUMENSTROM		SPANNUNG			SCHLAUCH		EINLASS/AUSLASS
			L/MIN	GPM	AC V./HZ DC VOLT	POWER WATT	AMP. MAX.	LÄNGE	Ø	SCHALTER
FO010020B	DELPHIN PRO 120/230V-50/60HZ		2 - 11	0,5 - 2,9	230/50	200	1,1	2 M	3/4"	JA
FO010021B	DELPHIN PRO 120/230V-50/60HZ W/SEC CONN		2 - 11	0,5 - 2,9	230/50	200	1,1	2 M	3/4"	JA

*KONFORM MIT ISO/FDIS 222241-4:2009